

EN Cordless hand-push lawn mower 36 V 46 cm

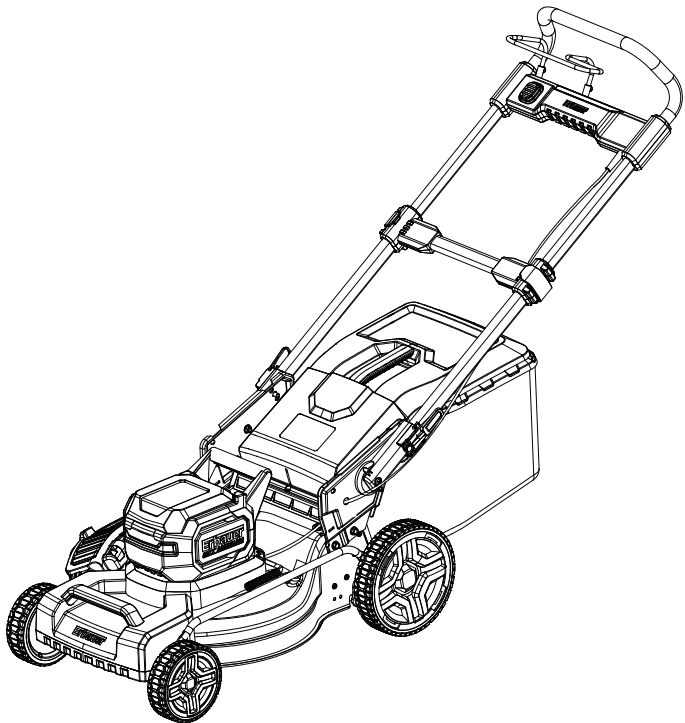

EN ORIGINAL INSTRUCTIONS

IMPORTANT - These instructions are for your safety. Please read through them thoroughly prior to handling the product and retain them for future reference.



V10724_5059340904955_MAND2_2324

ERT1042GLM
5059340904955
5059340904542
5063022544469

EN Parts

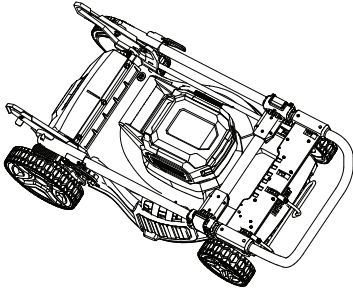

01. x1

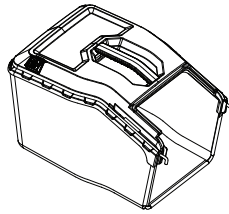

02. x1



03. x1

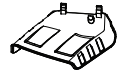

04. x1

EN You will need



(items not supplied)

Suitable personal protective equipment

Suitable wrench

Suitable lubricating oil

Battery pack (24)

Charger (25) and its manual

EN Contents

EN	
Product description	3
Safety	5
Guarantee	21
Preparation	22
Assembly	23
Functions & Settings	28
Use	33
Care and maintenance	37

EN Product description

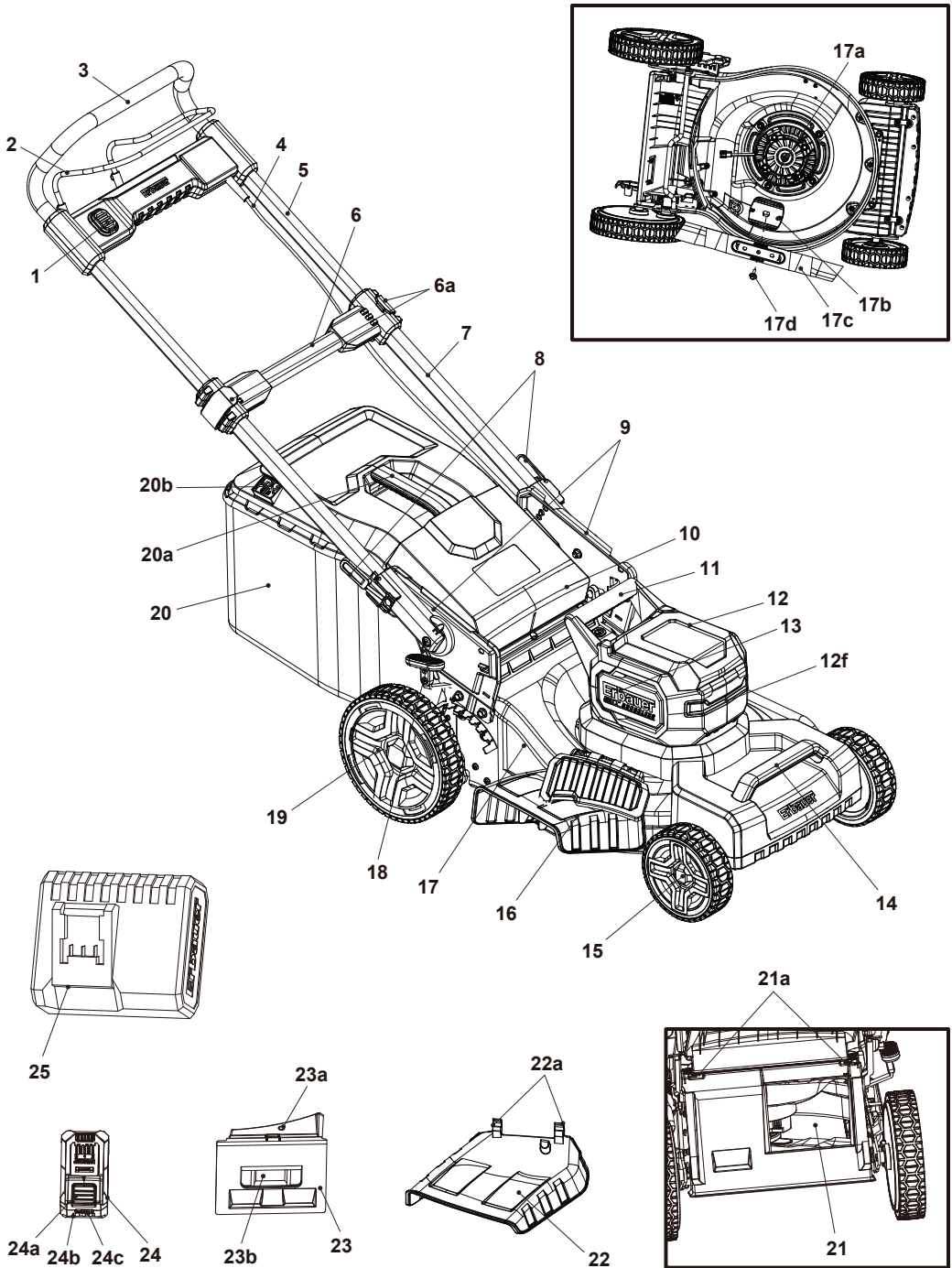

1. Safety switch button
2. Start lever
3. Grip handle
4. Control cord
5. Upper handle bar
6. Middle handle bar
 - a. Clamp lever (x2)
7. Lower handle bar
8. Lock lever (x2)
 - a. Lock pin*
9. Handle support (x2)
 - a. Hole* (x3)
10. Deflector guard
11. Rear transport handle
12. Battery compartment cover
 - a. Electrical contacts*
 - b. Sliding slots*
 - c. Battery display*
 - d. Lip*
 - e. Battery compartment*
 - f. Work lamp
13. Air vents
14. Front transport handle
15. Front wheel (x2)
16. Side deflector guard
17. Cutting blade compartment
 - a. Spindle
 - b. Blade holder
 - c. Cutting blade
 - d. Hex bolt with washers
18. Lever for cutting height adjustment
19. Rear wheel (x2)
20. Grass catcher
 - a. Carry handle
 - b. Hatch
 - c. Rubber clip* (x3)
 - d. Supporting rod*
 - e. Catcher hook* (x2)
21. Rear discharge chute
 - a. Spring hook (x2)
22. Side discharge attachment
 - a. Hook (x2)
23. Mulching insert
 - a. Locking latch
 - b. Recess handle
24. Battery pack (not included)
 - a. Release button
 - b. Battery capacity button
 - c. Battery capacity indicators
25. Charger (not included)



NOTE: Parts marked with * are not shown in this overview. Please refer to the respective part in the instruction manual.



General Machine Safety Warnings



WARNING! READ ALL SAFETY WARNINGS, INSTRUCTIONS, ILLUSTRATIONS AND SPECIFICATIONS PROVIDED WITH THIS MACHINE. FAILURE TO FOLLOW ALL INSTRUCTIONS LISTED BELOW MAY RESULT IN ELECTRIC SHOCK, FIRE AND/OR SERIOUS INJURY.

SAVE ALL WARNINGS AND INSTRUCTIONS FOR FUTURE REFERENCE.

The term “machine” in the warnings refers to your mains-operated (corded) machine or battery-operated (cordless) machine.

Work area safety

- **Keep work area clean and well lit.** Cluttered or dark areas invite accidents.
- **Do not operate machines in explosive atmospheres, such as in the presence of flammable liquids, gases or dust.** Machines create sparks which may ignite the dust or fumes.
- **Keep children and bystanders away while operating a machine.** Distractions can cause you to lose control.

Electrical safety

- **Machine plugs must match the outlet. Never modify the plug in any way. Do not use any adapter plugs with earthed (grounded) machines.** Unmodified plugs and matching outlets will reduce risk of electric shock.

- **Avoid body contact with earthed or grounded surfaces, such as pipes, radiators, ranges and refrigerators.** There is an increased risk of electric shock if your body is earthed or grounded.
- **Do not expose power tools to rain or wet conditions.** Water entering a power tool will increase the risk of electric shock.
- **Do not abuse the cord. Never use the cord for carrying, pulling or unplugging the machine. Keep cord away from heat, oil, sharp edges or moving parts.** Damaged or entangled cords increase the risk of electric shock.
- **When operating a machine outdoors, use an extension cord suitable for outdoor use.** Use of a cord suitable for outdoor use reduces the risk of electric shock.
- **If operating a machine in a damp location is unavoidable, use a residual current device (RCD) protected supply.** Use of an RCD reduces the risk of electric shock.

Personal safety

- **Stay alert, watch what you are doing and use common sense when operating a machine. Do not use a machine while you are tired or under the influence of drugs, alcohol or medication.** A moment of inattention while operating machines may result in serious personal injury.
- **Use personal protective equipment. Always wear eye protection.** Protective equipment such as dust mask, non-skid safety shoes, hard hat, or hearing protection used for appropriate conditions will reduce personal injuries.
- **Prevent unintentional starting. Ensure the switch is in the off-position before connecting to power source and/or battery pack, picking up or carrying the machine.** Carrying machines with your finger on the switch or energising machines that have the switch on invites accidents.
- **Remove any adjusting key or wrench before turning the machine on.** A wrench or a key left attached to a rotating part of the machine may result in personal injury.

- **Do not overreach. Keep proper footing and balance at all times.** This enables better control of the machine in unexpected situations.
- **Dress properly. Do not wear loose clothing or jewellery. Keep your hair and clothing away from moving parts.** Loose clothes, jewellery or long hair can be caught in moving parts.
- **If devices are provided for the connection of dust extraction and collection facilities, ensure these are connected and properly used.** Use of dust collection can reduce dust-related hazards.
- **Do not let familiarity gained from frequent use of machines allow you to become complacent and ignore machine safety principles.** A careless action can cause severe injury within a fraction of a second.

Machine use and care

- **Do not force the machine. Use the correct machine for your application.** The correct machine will do the job better and safer at the rate for which it was designed.
- **Do not use the machine if the switch does not turn it on and off.** Any machine that cannot be controlled with the switch is dangerous and must be repaired.
- **Disconnect the plug from the power source and/or remove the battery pack, if detachable, from the machine before making any adjustments, changing accessories, or storing machines.** Such preventive safety measures reduce the risk of starting the machine accidentally.
- **Store idle machines out of the reach of children and do not allow persons unfamiliar with the machine or these instructions to operate the machine.** Machines are dangerous in the hands of untrained users.
- **Maintain machines and accessories. Check for misalignment or binding of moving parts, breakage of parts and any other condition that may affect the machine's operation. If damaged, have the machine repaired before use.** Many accidents are caused by poorly maintained machines.

- **Keep cutting machines sharp and clean.** Properly maintained cutting machines with sharp cutting edges are less likely to bind and are easier to control.
- **Use the machine, accessories and machine bits etc. in accordance with these instructions, taking into account the working conditions and the work to be performed.** Use of the machine for operations different from those intended could result in a hazardous situation.
- **Keep handles and grasping surfaces dry, clean and free from oil and grease.** Slippery handles and grasping surfaces do not allow for safe handling and control of the machine in unexpected situations.

Battery machine use and care

- **Recharge only with the charger specified by the manufacturer.** A charger that is suitable for one type of battery pack may create a risk of fire when used with another battery pack.
- **Use machines only with specifically designated battery packs.** Use of any other battery packs may create a risk of injury and fire.
- **When battery pack is not in use, keep it away from other metal objects, like paper clips, coins, keys, nails, screws or other small metal objects that can make a connection from one terminal to another.** Shorting the battery terminals together may cause burns or a fire.
- **Under abusive conditions, liquid may be ejected from the battery; avoid contact. If contact accidentally occurs, flush with water. If liquid contacts eyes, additionally seek medical help.** Liquid ejected from the battery may cause irritation or burns.
- **Do not use battery pack or machine that is damaged or modified.** Damaged or modified batteries may exhibit unpredictable behaviour resulting in fire, explosion or risk of injury.

- **Do not expose a battery pack or machine to fire or excessive temperature.** Exposure to fire or temperature above 130 °C may cause explosion.
- **Follow all charging instructions and do not charge the battery pack or machine outside the temperature range specified in the instructions.** Charging improperly or at temperatures outside the specified range may damage the battery and increase the risk of fire.

Service

- **Have your machine serviced by a qualified repair person using only identical replacement parts.** This will ensure that safety of the machine is maintained.
- **Never service damaged battery packs.** Service of battery packs should only be performed by the manufacturer or authorized service providers.

Lawnmower Safety Warnings

- **Do not use the lawnmower in bad weather conditions, especially when there is a risk of lightning.** This decreases the risk of being struck by lightning.
- **Thoroughly inspect the area for wildlife where the lawnmower is to be used.** Wildlife may be injured by the lawnmower during operation.
- **Thoroughly inspect the area where the lawnmower is to be used and remove all stones, sticks, wires, bones, and other foreign objects.** Thrown objects can cause personal injury.
- **Before using the lawnmower, always visually inspect to see that the blade and the blade assembly are not worn or damaged.** Worn or damaged parts increase the risk of injury.
- **Check the grass catcher frequently for wear or deterioration.** A worn or damaged grass catcher may increase the risk of personal injury.
- **Keep guards in place. Guards must be in working order and be properly mounted.** A guard that is loose, damaged, or is not functioning correctly may result in personal injury.

- **Keep all cooling air inlets clear of debris.** Blocked air inlets and debris may result in overheating or risk of fire.
- **While operating the lawnmower, always wear non-slip and protective footwear. Do not operate the lawnmower when barefoot or wearing open sandals.** This reduces the chance of injury to the feet from contact with the moving blade.
- **While operating the lawnmower, always wear long trousers.** Exposed skin increases the likelihood of injury from thrown objects.
- **Do not operate the lawnmower in wet grass. Walk, never run.** This reduces the risk of slipping and falling which may result in personal injury.
- **Do not operate the lawnmower on excessively steep slopes.** This reduces the risk of loss of control, slipping and falling which may result in personal injury.
- **When working on slopes, always be sure of your footing, always work across the face of slopes, never up or down and exercise extreme caution when changing direction.** This reduces the risk of loss of control, slipping and falling which may result in personal injury.
- **Use extreme caution when reversing or pulling the lawnmower towards you. Always be aware of your surroundings.** This reduces the risk of tripping during operation.
- **Do not touch blades and other hazardous moving parts while they are still in motion.** This reduces the risk of injury from moving parts.
- **When clearing jammed material or cleaning the lawnmower, make sure all power switches are off and the battery pack is disconnected.** Unexpected operation of the lawnmower may result in serious personal injury.

Additional safety instructions for lawn mower

Training

- Read the instructions carefully. Be familiar with the controls and the proper use of the product.
- Never allow children, persons with reduced physical, sensory or mental capabilities or lack of experience and knowledge or people unfamiliar with these instructions to use the product. Local regulations may restrict the age of the operator.
- Children should be supervised to ensure that they do not play with the product.
- Cleaning and user maintenance shall not be made by children without supervision.
- Never mow while people, especially children, or pets are nearby.
- Keep in mind that the operator or user is responsible for accidents or hazards occurring to other people or their property.

Preparation

- While mowing, always wear substantial footwear and long trousers. Do not operate the product when barefoot or wearing open sandals. Avoid wearing clothing that is loose fitting or that has hanging cords or ties.
- Thoroughly inspect the area where the product is to be used and remove all objects which can be thrown by the product.
- Before using, always visually inspect to see that the cutting blade, cutting blade bolts and cutting blade assembly are not worn or damaged. Replace worn or damaged cutting blades and bolts in sets to preserve balance. Replace damaged or unreadable labels.



CAUTION! DO NOT TOUCH A ROTATING CUTTING BLADE.

Operation

- Operate the product only in daylight or in good artificial light.
- Avoid operating the product in wet grass, where feasible.
- Always be sure of your footing on slopes.
- Walk, never run.
- Mow across the face of slopes, never up and down.
- Exercise extreme caution when changing direction on slopes.
- Do not mow excessively steep slopes.
- Use extreme caution when reversing or pulling the product towards you.
- Stop the cutting blade(s) if the product has to be tilted for transportation when crossing surfaces other than grass, and when transporting the product to and from the area to be mowed.
- Never operate the product with defective guards or shields, or without safety devices, for example deflectors and/or grass catchers, in place.
- Start the product or switch on the product carefully according to instructions and with feet well away from the cutting blade(s).
- Do not tilt the product when switching on the motor, except if the product has to be tilted for starting. In this case, do not tilt it more than absolutely necessary and lift only the part, which is away from the operator.
- Do not start the product when standing in front of the discharge chute.
- Do not put hands or feet near or under rotating parts. Keep clear of the discharge opening at all times.
- Do not transport the product while the battery pack is inserted.
- Stop the product and remove the battery pack. Make sure that all moving parts have come to a complete stop:
 - whenever you leave the product,
 - before clearing blockages or unclogging chute,
 - before checking, cleaning or working on the product,
 - after striking a foreign object. Inspect the product for damage and make repairs before restarting and operating the product.

- If the product starts to vibrate abnormally (check immediately)
 - inspect for damage,
 - replace or repair any damaged parts,
 - check for and tighten any loose parts.

Maintenance and storage

- Remove the battery pack before checking, cleaning or working on the product and when it is not in use.
- Remove the battery pack before carrying out maintenance or cleaning work.
- Improper maintenance will lead to malfunction/failure of the product.
- Inspect and maintain the product regularly. Keep all nuts, bolts and screws tight to be sure the product is in safe working condition.
- Check the grass catcher frequently for wear or deterioration.
- Be careful during adjustment of the product to prevent entrapment of the fingers between moving blades and fixed parts of the product.
- Always allow the product to cool down before storing in any enclosure.
- When servicing the blades be aware that, even though the power source is switched off, the blades can still be moved.
- Replace worn or damaged parts for safety. Use only genuine replacement parts and accessories.
- Wear strong work gloves when removing and re-assembling the cutting blade.
- Have the product repaired only by an authorised service centre or similar qualified specialist.
- When not in use, store the product out of the reach of children.

Additional safety warnings for battery pack

- **Battery pack needs to be charged before use.** Always refer to the charger's instruction and charge it properly.
- **Remove the battery pack from the product when not in use.**
- **Don't maintain the battery pack on the charger when not in use.**
- **After extended periods of storage, it may be necessary to charge and discharge the battery pack several times to obtain the maximum performance.**
- **Longer life and better performance can be obtained if the battery is charged when the air temperature is between 18 °C and 24 °C.** Do not charge the battery in air temperature below 5 °C or above 40 °C. This is important as it can prevent serious damage to the battery.
- **Do not charge battery in a damp or wet location.** Following this rule will reduce the risk of electric shock.
- **Do not disassemble the battery and avoid mechanical damage to the battery. Risk of short circuit and fumes may be emitted.** Ensure fresh air and seek medical assistance in the event of discomfort.
- **When disposing of battery pack, keep the battery pack of different electrochemical systems separate from each other.**
- Do not connect the positive terminal and negative terminal of the battery to each other with any metal object (such as wire).
- Do not carry or store battery together with necklaces, hairpins or other metal objects.
- Do not pierce the battery with nails, strike the battery with a hammer, step on the battery or otherwise subject it to strong impacts or shocks.
- Do not solder directly onto the battery.
- Do not expose battery to water or salt water, or allow the battery to get wet.
- Do not disassemble or modify the battery.

- Do not place the battery in or near fire, on stoves or on other high temperature locations. Do not place the battery in direct sunlight, or use or store the battery inside cars in hot weather.
- Do not place the battery in microwave ovens, high pressure containers or on induction cookware.
- If you intend to store a battery for a period without use then store battery at room temperature (19 °C to 25 °C), charged to 3 bars on the charger indicator lights. When storing for very long periods boost charge the battery once per year to prevent over discharge.

Health surveillance

All employees should be part of an employer's health surveillance scheme to help identify any vibration related diseases at an early stage, prevent disease progression and help employees stay in work.

Vibration and noise reduction

To reduce the impact of noise and vibration emission, limit the time of operation, use low-vibration and low-noise operating modes as well as wear personal protective equipment.

Take the following points into account to minimise the vibration and noise exposure risks:

- Only use the product as intended by its design and these instructions.
- Ensure that the product is in good condition and well maintained.
- Use correct attachments for the product and ensure they are in good condition.
- Keep tight grip on the handles/grip surface.
- Maintain this product in accordance with these instructions and keep it well lubricated (where appropriate).
- Plan your work schedule to spread any high vibration machine use across a longer period of time.

- Prolonged use of the product exposes the user to vibrations that can cause a range of conditions collectively known as hand-arm vibration syndrome (HAVS) e.g. fingers going white; as well as specific diseases such as carpal tunnel syndrome. To reduce this risk when using the product, always wear protective gloves and keep your hands warm.

Emergency

Familiarise yourself with the use of this product by means of this instruction manual. Memorise the safety directions and follow them to the letter. This will help to prevent risks and hazards.

- **Always be alert when using this product, so that you can recognise and handle risks early.** Fast intervention can prevent serious injury and damage to property.
- **Switch the product off and remove the battery pack if there are malfunctions.** Have the product checked by a qualified professional and repaired, if necessary, before you operate it again.

Residual risks

Even if you are operating this product in accordance with all the safety requirements, potential risks of injury and damage remain. The following dangers can arise in connection with the structure and design of this product:

- Health defects resulting from vibration emission if the product is being used over long periods of time or not adequately managed and properly maintained.
- Injuries and damage to property due to broken attachments or the sudden impact of hidden objects during use.
- Danger of injury and property damage caused by flying objects or poor machine accessories.



WARNING! THIS PRODUCT PRODUCES AN ELECTROMAGNETIC FIELD DURING OPERATION! THIS FIELD MAY UNDER SOME CIRCUMSTANCES INTERFERE WITH ACTIVE OR PASSIVE MEDICAL IMPLANTS! TO REDUCE THE RISK OF SERIOUS OR FATAL INJURY, WE RECOMMEND PERSONS WITH MEDICAL IMPLANTS TO CONSULT THEIR DOCTOR AND THE MEDICAL IMPLANT MANUFACTURER BEFORE OPERATING THIS PRODUCT!

Symbols

On the product, the rating label and within these instructions you will find among others the following symbols and abbreviations. Familiarise yourself with them to reduce hazards like personal injuries and damage to property.

V	Volt, (direct current voltage)	mAh	Milliampere per hour
/min or min ⁻¹	Per minute	°C	Degree Celsius
n ₀	No-load speed	L	Litre
g	Gram	kg	Kilogram
mm	Millimetre	cm	Centimeter
m	Metre	A	Ampere
dB(A)	Decibel (A-rated)	m/s ²	Metres per seconds squared



Lock / to tighten or secure.



Unlock / to loosen.



Read the instruction manual.



Note / Remark.



Caution / Warning.

yyWxx

Manufacturing date code; year of manufacturing (20yy) and week of manufacturing (Wxx).

IPX1

Protected against vertically falling water drops.



Always wear ear protection.



Always wear eye protection.



Wear a dust mask.



Wear protective gloves.



Wear protective, slip-resistant footwear.



Wear tight-fitted protective clothes.



WARNING – Disconnect battery before maintenance!

Switch the product off and remove battery pack before assembly, cleaning, adjustments, maintenance, storage and transportation.



This product is of protection class III.



Do not expose the product to rain or wet conditions (moisture).



Mow across the face of slopes, never up and down.



Inspect the area where the product is to be used and remove all objects which can be thrown by the product. If objects are hidden while operating stop the motor and remove the object.



WARNING - Beware of thrown objects - keep bystanders away!

Objects thrown by the product could hit the user or other bystanders. Always ensure that other people and pets remain at a safe distance from the product when it is in operation. In general, children must not come near the area where the product is.



WARNING - Keep hands and feet away from the blades!

Danger of injury! When cleaning, repairing, or inspecting, make certain the cutting blade and all mowing parts have stopped.



DANGER - Keep hands and feet away!



Cutting blade continues to rotate after the product is switched off. Wait until all machine components have completely stopped before touching the product.



Pay special attention when working on the cutting blade!



Grass catcher is ready for grass collection.



Grass catcher is full, empty it.



Guaranteed sound power level value in 92 dB(A).



WEEE symbol. Waste electrical products should not be disposed of with household waste. Please recycle where facilities exist. Check with your Local Authority or local store for recycling advice.



Crossed out dust bin. Batteries and battery packs should not be disposed of with household waste. Please recycle where facilities exist. Check with your Local Authority or local store for recycling advice.



Do not dispose of battery packs in rivers or immerse in water.



Do not dispose of battery packs in fire. They will explode and cause injury.



Do not expose battery packs to heat in excess of 40 °C.

Do not charge or store the battery pack in temperatures below 5 °C (41 °F) and above 40 °C (104°F).



The product complies with the applicable European directives and an evaluation method of conformity for these directives was done.



UK Conformity Assessed.

Rating label explanation

ERT1042GLM = Model number

ERT = Erbauer (brand)

1042 = Sequential code

GLM = Grass Lawn Mower

Technical specifications

General

- > Rated voltage : 36 V $\overline{\text{---}}$
- > Rated no load speed n_0 : 2800 min⁻¹
- > Max. cutting width : 46 cm
- > Cutting height range : 25 - 75 mm, 7 levels
- > Grass catcher volume : 60 L
- > Protection class : III
- > Degree of protection : IPX1
- > Wheel size : \varnothing 175 x 50 mm (Front wheel)
 \varnothing 200 x 50 mm (Rear wheel)
- > Weight : approx. 24.6 kg
- > Dimensions : approx. 170 x 54.5 x 107 cm

Battery pack

- > Model no. : ERT1044BAT
- > Type : Li-Ion, 10 INR 21700 cells
- > Capacity : 8000 / 4000 mAh
- > Voltage : 18 / 36V $\overline{\text{---}}$
- > Weight : approx. 0.69 kg

Charger for battery pack

- > Model no. : ERT1046CHR
- > Rated output : 2 x 21 V $\overline{\text{---}}$ 12 A

Usable battery pack (sold separately)

- > Model no. : ERT1045BAT
- > Capacity : 6000 / 3000 mAh
- > Voltage : 18 / 36 V $\overline{\text{---}}$

Usable charger (sold separately)

- > Model no. : ERT1047CHR
- > Rated output : 21 V $\overline{\text{---}}$, 12 A
- > Ambient temperature range for machine charger and battery use : 5 to 40 °C

Sound values

- > Sound pressure level L_{pA} : 80.8 dB(A)
- > Uncertainty K_{pA} : 3 dB(A)
- > Measured sound power level L_{WA} : 95.6 dB(A)
- > Uncertainty K_{WA} : 3 dB(A)
- > Guaranteed sound power level L_{WA} (according to 2000/14/EC amended by 2005/88/EC): 92 dB(A)

Vibration values

- Hand arm vibration $a_{h,w}$: 0.346 m/s²
- Uncertainty K : 1.5 m/s²

The sound values have been determined according to noise test code given in EN 62841-1, EN IEC 62841-4-3 using the basic standards EN ISO 11094 and EN ISO 3744.

The sound intensity level for the operator may exceed 80 dB(A) and ear protection measures are necessary.

The declared vibration total values and the declared noise emission values have been measured in accordance with a standard test method (EN 62841-1, EN IEC 62841-4-3) and may be used for comparing one machine with another; they may also be used in a preliminary assessment of exposure.



WARNING! THE VIBRATION AND NOISE EMISSION DURING ACTUAL USE OF THE MACHINE CAN DIFFER FROM THE DECLARED TOTAL VALUE DEPENDING ON THE WAYS IN WHICH THE MACHINE IS USED ESPECIALLY WHAT KIND OF WORKPIECE IS PROCESSED.

THE NEED TO IDENTIFY SAFETY MEASURES TO PROTECT THE OPERATOR THAT ARE BASED ON AN ESTIMATION OF EXPOSURE IN THE ACTUAL CONDITIONS OF USE (TAKING ACCOUNT OF ALL PARTS OF THE OPERATING CYCLE SUCH AS THE TIMES WHEN THE MACHINE IS SWITCHED OFF AND WHEN IT IS RUNNING IDLE IN ADDITION TO THE TRIGGER TIME).

Recycling and disposal



Waste electrical products should not be disposed of with household waste. Please recycle where facilities exist. Check with your local authority or local store for recycling advice.

For further information visit www.recycle-more.co.uk.

The product comes in a package that protects it against damage during shipping. Keep the package until you are sure that all parts have been delivered and the product is working properly. Recycle the package afterwards.

Disposal of an exhausted battery pack



The battery is Li-Ion type. To preserve natural resources, please recycle or dispose of the battery pack properly. Consult your local waste authority for information regarding available recycling and / or disposal options.

Discharge your battery pack by operating your machine, then remove the battery pack from the machine and cover the battery pack connections with heavy duty adhesive tape to prevent short circuit and energy discharge.

Do not attempt to open or remove any of the components.

Guarantee

We take special care to select high quality materials and use manufacturing techniques that allow us to create products incorporating design and durability. This product has a manufacturer's guarantee of 3 years against manufacturing defects, from the date of purchase (if bought in store) or date of delivery (if bought online), at no additional cost for normal (non-professional or commercial) household use.

To make a claim under this guarantee, you must present your proof of purchase (such as a sales receipt, purchase invoice or other evidence admissible under applicable law), please keep your proof of purchase in a safe place. For this guarantee to apply, the product you purchased must be new, it will not apply to second hand or display products. Unless stated otherwise by applicable law, any replacement product issued under this guarantee will only be guaranteed until expiry of the original period guarantee period.

This guarantee covers product failures and malfunctions provided the product was used for the purpose for which it is intended and subject to installation, cleaning, care and maintenance in accordance with the information contained in these terms and conditions, in the user manual and standard practice, provided that standard practice does not conflict with the user manual.

This guarantee does not cover defects and damage caused by normal wear and tear or damage that could be the result of improper use, faulty installation or assembly, neglect, accident, misuse, or modification of the product. Unless stated otherwise by applicable law, this guarantee will not cover, in any case, ancillary costs (shipping, movement, costs of uninstalling and reinstalling, labour etc), or direct and indirect damage.

This guarantee does not cover defects and damage caused by or resulting from:

- Normal wear and tear
- Overload, misuse or neglect
- Repairs attempted by anyone other than an authorised agent
- Cosmetic damage
- Damage caused by foreign objects, substances or accidents
- Accidental damage or modification
- Failure to follow manufacturer's guidelines
- Loss of use of the goods

If this product is defective, we will, within a reasonable time, repair, replace, refund, service, or spare parts.

Rights under this guarantee are enforceable in the country in which you purchased this product. Guarantee related queries should be addressed to the store you purchased this product from.

The guarantee is in addition to and does not affect your statutory rights.

IMPORTANT - RETAIN THIS INFORMATION FOR FUTURE REFERENCE: READ CAREFULLY

EN Preparation

Unpacking



NOTE: The product is heavy, ask another person for assistance if required.

1. Unpack all parts and lay them on a flat, stable surface.
2. Remove all packing materials and shipping devices if applicable.
3. Make sure the delivery contents are complete and free of any damage. If you find that parts are missing or show damage do not use the product but contact your dealer. Using an incomplete or damaged product represents a hazard to people and property.
4. Ensure that you have all the accessories and machines needed for assembly and operation. This also includes suitable personal protective equipment.



WARNING! THE PRODUCT AND THE PACKAGING ARE NOT CHILDREN'S TOYS! CHILDREN MUST NOT PLAY WITH PLASTIC BAGS, SHEETS AND SMALL PARTS! THERE IS A DANGER OF CHOKING AND SUFFOCATION!

You will need

(items not supplied)

Suitable personal protective equipment
Suitable wrench
Suitable lubricating oil
Battery pack (24)
Charger (25) and its manual

(items supplied)

Cutting blade (17c)
Grass catcher (20)
Side discharge attachment (22)
Mulching insert (23)



NOTE: The accessories required depend on the intended application. Ask your dealer for advice.

EN Assembly

WARNING! THE PRODUCT MUST BE FULLY ASSEMBLED BEFORE OPERATION!

DO NOT USE A PRODUCT THAT IS ONLY PARTLY ASSEMBLED OR ASSEMBLED WITH DAMAGED PARTS!



WEAR PROTECTIVE GLOVES FOR THIS ASSEMBLY WORK AND ALWAYS LAY THE PRODUCT ON A FLAT AND STABLE SURFACE WHILE ASSEMBLING.



FOLLOW THE ASSEMBLY INSTRUCTIONS STEP-BY-STEP AND USE THE PICTURES PROVIDED AS A VISUAL GUIDE TO EASILY ASSEMBLE THE PRODUCT!



BEFORE USING THE PRODUCT, FAMILIARISE YOURSELF WITH THE OPERATING FEATURES READ THE ENTIRE INSTRUCTION MANUAL PAYING PARTICULAR ATTENTION TO THE SAFETY RULES AND OPERATING PROCEDURES.

DO NOT CONNECT THE PRODUCT TO BATTERY PACK (24) BEFORE IT IS COMPLETELY ASSEMBLED!

Handle assembly

The handle assembly of the upper handle bar (5) and the lower handle bar (7) is preinstalled on the handle supports (9).

1. Squeeze and disengage the two lock levers (8) on both sides of the lower handle bar (7) (Fig.1, step 1).
2. Hold the two lock levers (8) in position and fold up the handle assembly anticlockwise to leave its locking position (Fig. 1, step 2). Make sure that the control cord (4) runs on the lower handle bar (7).

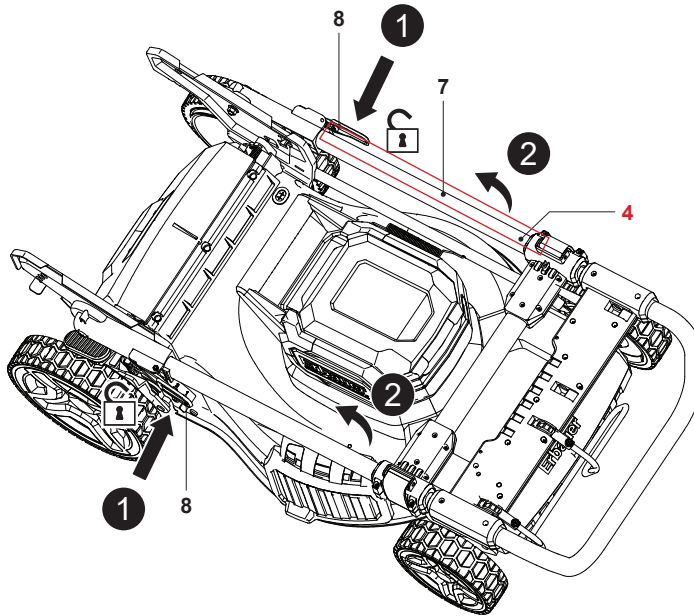

Fig. 1

3. Grasp the grip handle (3) and keep rotating the handle assembly until the lock pin (8a) of the lock lever (8) automatically engaged in one of the holes (9a) of the handle support (9), depended on the need of handle height; Rotate the two lock levers (8) clockwise to secure the assembly (Fig. 2, steps 1, 2).

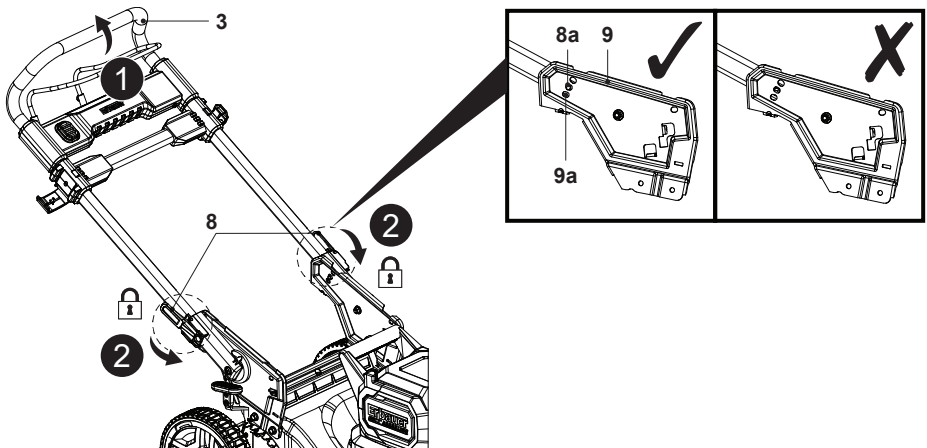

Fig. 2



WARNING! MAKE SURE THE TWO LOCK LEVERS (8) ARE PROPERLY SECURED BEFORE USING THE PRODUCT.



NOTE: For first assembly, secure the handle assembly with the two lock levers (8) in the middle position of the tilt adjustment mechanism. Ensure the handle assembly is assembled on the same height level on both sides.

4. Pull open the two clamp levers (6a), then grasp the grip handle (3) and gradually pull out upper handle bar (5) all the way until an audible click is heard (Fig. 3, steps 1, 2).

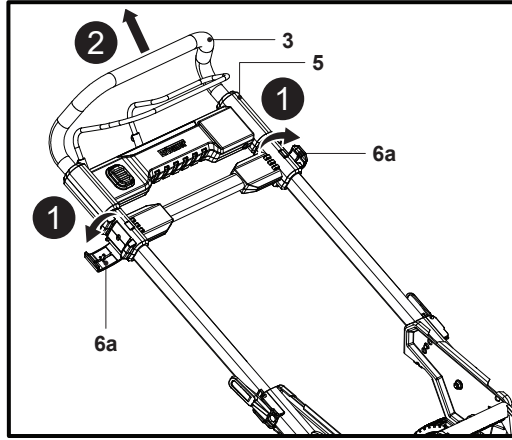

Fig. 3

5. Close the two clamp levers (6a) and check whether the upper handle bar (5) is secured.

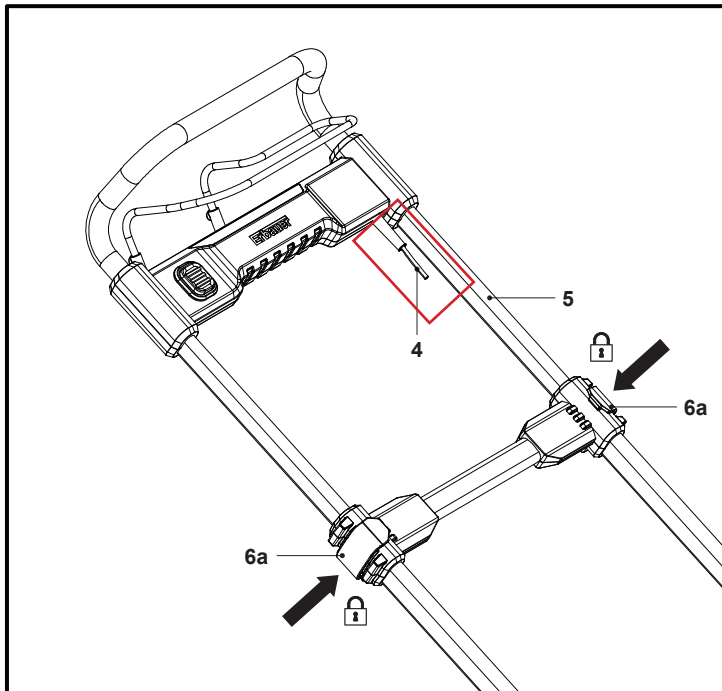

Fig. 4



NOTE: Pull or push the upper handle bar (5) gently. Do not use sudden force! The upper handle bar (5) can't be secured at middle position.

6. Check the condition of the control cord (4) and keep it away from the rear wheel (19).

Grass catcher

1. The grass catcher (20) is partly assembled at delivery status.
2. Clip the three rubber clips (20c) onto the supporting rod (20d) of the grass catcher (20) (Fig. 5) and the grass catcher (20) is ready for use.

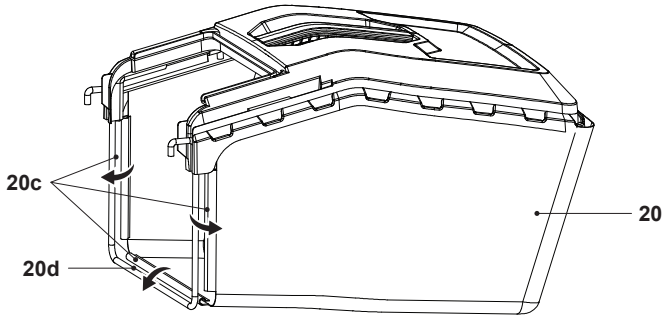

Fig. 5

i **NOTE:** The mulching insert (23) must be removed before fitting the grass catcher (20).

Before you fit the grass catcher (20) onto the lawn mower you must ensure that the motor is switched off and the cutting blade is not rotating.

3. Open the deflector guard (10) and hold it in position (Fig. 6, step 1).
4. Carry the grass catcher (20) by its carry handle (20a).
5. Align the two catcher hooks (20e) with the spring hooks (21a) and hang the grass catcher (20) onto it (Fig. 6, step 2).
6. Carefully release the deflector guard (10) afterward.

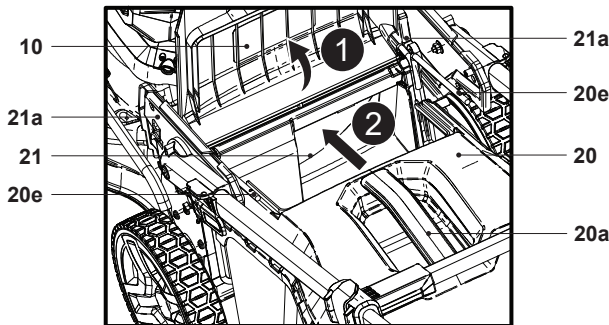

Fig. 6

i **NOTE:** Always carry the grass catcher (20) by its carry handle (20a).
Before hooking the grass catcher (20), check if the mulching insert (23) is in the rear discharge chute (21). Take away the mulching insert (23) before hooking the grass catcher (20).

Battery pack (not included)

Attaching the battery pack

1. Hold the lip (12d) and open the battery compartment cover (12) (Fig. 7, step 1).
2. Align the battery pack (24) with the sliding slots (12b) of the battery compartment (12e) and slide the battery pack (24) in to attach it (Fig. 7, step 2).

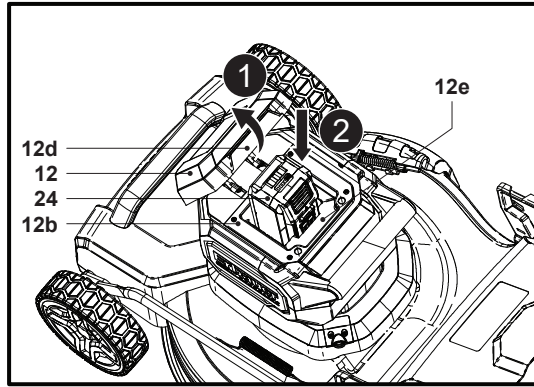

Fig. 7

3. Make sure that the electrical contacts (12a) are fully inserted into the battery pack (24) and that it snaps in place with a click.
4. The battery pack (24) can only be installed in one direction.
5. Close the battery compartment cover (12).

Releasing the battery pack

The battery pack (24) can't be charged whilst in the lawn mower. Remove the battery pack (24) from its battery compartment (12e) for charging.

1. Hold the lip (12d) and open the battery compartment cover (12) (Fig. 8, step 1).
2. Press down the release button (24a) to unlock the latch of battery pack (24) (Fig. 8, step 2).
3. Slide out the battery pack (24) from the battery compartment (12e) (Fig. 8, step 3)
4. Close the battery compartment cover (12).

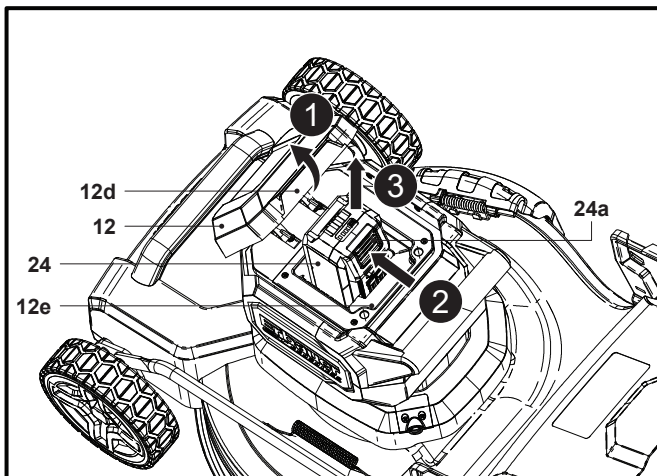

Fig. 8

Charging the battery pack

The battery pack (24) has been shipped in a low charge condition. Charge it fully before first use.

Refer to the charger's instruction manual for the details.

Battery capacity indicators

The battery pack (24) is equipped with battery capacity indicators (24c) which are used to give an indication of the battery pack's remaining capacity. Press the battery capacity button (24b) to check battery capacity (Fig. 9). The LEDs will stay lit for approximately 3 seconds.

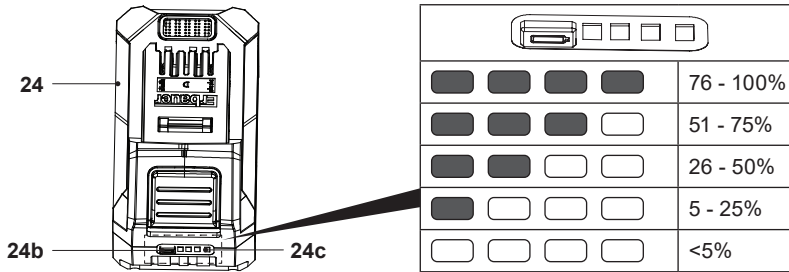

Fig. 9

EN Functions & Settings

Intended use

This cordless lawn mower ERT1042GLM is designated with a rated voltage of 36 V --- . It is designed only to be used with the battery pack which is listed in the chapter of "Technical specifications".

The product is intended for mowing grass in domestic gardens only. It must not be used to mow unusually high, dry or wet grass, e.g. pasture grass, or to shred leaves.

The use of this product in case of rain or humid environment is prohibited.

For safety reasons it is essential to read the entire instruction manual before first operation and to observe all the instructions therein.

This product is intended for private domestic use only, not for any commercial trade use. It must not be used for any purposes other than those described.

Handle height adjustment



WARNING! SWITCH THE PRODUCT OFF AND WAIT THAT THE CUTTING BLADE HAS COME TO A COMPLETE STOP BEFORE ADJUSTING THE HANDLE HEIGHT !



TO ENSURE SAFE OPERATION THE HEIGHT ADJUSTMENT OF THE HANDLE BAR IS LIMITED TO THE INDICATED POSITIONS! DO NOT ATTEMPT TO ADJUST ANY OTHER HEIGHT!

Adjust the handle assembly to a suitable height according to your needs. There are three handle heights to choose.

1. Squeeze and disengage the two lock levers (8) on both sides of the lower handle bar (7) (Fig.10, step 1).
2. Hold the two lock levers (8) in position, then grasp the grip handle (3) and swing the handle assembly gently (Fig. 10, step 2) until the lock pin (8a) of the lock lever (8) automatically engaged in one of the other two holes (9a) of the handle support (9).
3. Ensure the handle assembly is assembled on the same height level on both sides.

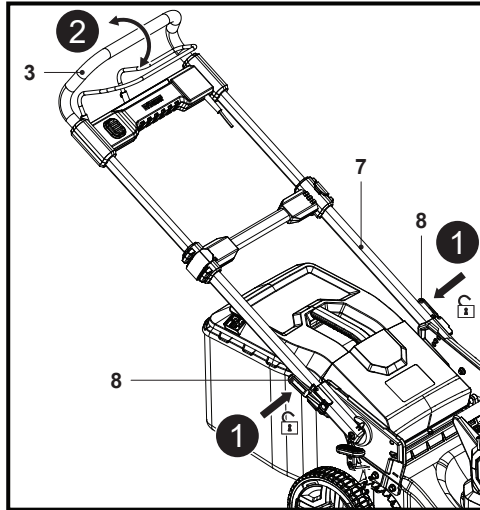

Fig. 10

Cutting height adjustment

WARNING! SWITCH THE PRODUCT OFF AND WAIT THAT THE CUTTING BLADE HAD COME TO A COMPLETE STOP BEFORE ADJUSTING THE CUTTING HEIGHT!

ENSURE THAT THE LEVER ENGAGES BETWEEN TWO OF THE PRONGS!



FOR THE FIRST CUT OF THE SEASON, A SUITABLE CUTTING HEIGHT SHOULD BE CHOSEN. DO NOT CHOOSE A LOW CUTTING HEIGHT IF THE GRASS IS LONG AND GREASY, THE MOTOR MAY NOT BE ABLE TO BOOT PROPERLY.

WHEN STARTING THE MOWER DO AN AUDIT OF THE HEIGHT OF THE GRASS. IF THE GRASS IS TOO TALL, THE MOWER WILL NOT START. IT WILL THEN INCREASE THE CUTTING HEIGHT. THIS FEATURE ALLOWS YOU TO SAVE THE ENGINE AND IMPROVE THE LIFE OF BATTERIES.

Adjust the cutting height according to the needs of your lawn. The cutting height depends on the kind of lawn and its actual height. When mowing high grass, start with the maximum cutting height and make a second cut with a lower cutting height.

1. Pull the lever (18) towards the rear wheel (19) (Fig. 11, step 1).
2. Move the lever (18) forward or backward to adjust the cutting height (Fig. 11, step 2).
3. Release the lever (18) and ensure it engaged in the slot properly (Fig. 11, step 3).

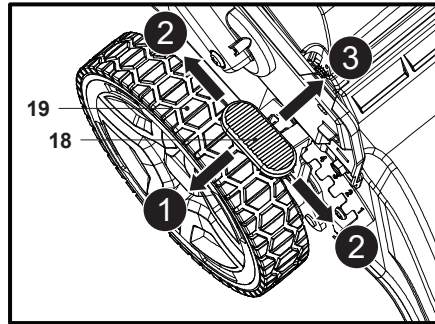

Fig. 11



WARNING! ENSURE THAT THE LEVER (18) ENGAGES IN THE SLOT AFTER EACH ADJUSTMENT.



NOTE: There are 7 cutting height levels available. The adjustable heights are 25 / 30 / 36 / 45 / 53 / 61 / 75 mm.

Grass catcher



WARNING! DO NOT ATTEMPT TO USE THE PRODUCT WITHOUT THE GRASS CATCHER ATTACHED WHEN COLLECTING GRASS - DANGER OF FLYING OBJECTS!

WHEN USING THE PRODUCT WITHOUT THE GRASS CATCHER (20), INSERT THE MULCHING INSERT (23).

SWITCH THE MOTOR OFF AND WAIT THAT THE CUTTING BLADE HAD COME TO A COMPLETE STOP BEFORE REMOVING THE GRASS CATCHER (20)!

Attach the grass catcher (20). Always carry the grass catcher (20) by its carry handle (20a).

Indicator

The grass catcher (20) is equipped with a hatch (20b) that indicates the filling during operation.

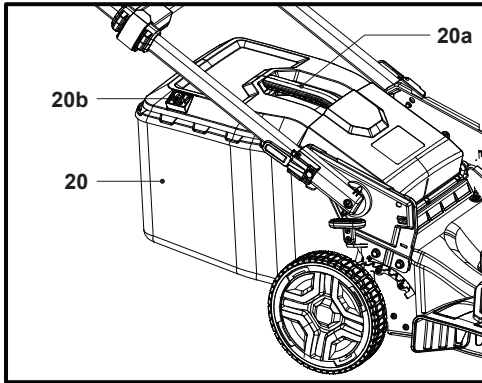

Fig. 12

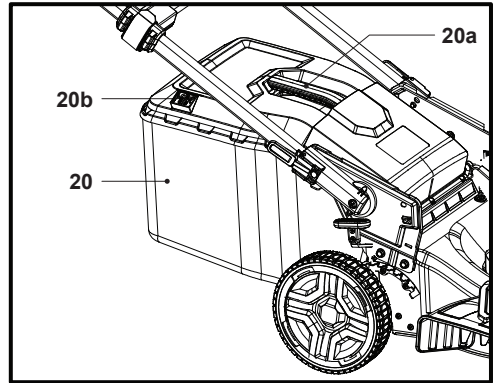

Fig. 13

1. When the hatch (20b) is opened the grass catcher (20) has sufficient volume left to collect grass (Fig. 12).
2. When the hatch (20b) is closed, the grass catcher (20) is full and must be emptied (Fig. 13).

Emptying

Empty the grass catcher (20) frequently during use. Do not wait until it is completely full. We recommend emptying it when it is half full.



NOTE: A full grass catcher (20) will reduce the performance of this product.

1. Switch the product off and make sure that the motor has stopped and the cutting blade has stopped rotating.
2. Open the deflector guard (10) and lift the grass catcher (20) off the spring hooks (21a).
3. Remove the grass clippings from the rear discharge chute (21) into the grass catcher (20). Use a proper machine such as a brush.
4. Remove the grass catcher (20) by its carry handle (20a).
5. Empty the grass clippings onto a compost heap.
6. Re-fit the grass catcher (20) to the product.



WARNING! NEVER USE YOUR HANDS OR FEET TO REMOVE GRASS CLIPPINGS FROM THE REAR DISCHARGE CHUTE (21)!



Mulching insert

The mulching insert (23) prevents grass from being collected by blocking the rear discharge chute (21).

This allows the grass clippings to be deposited back on the lawn during cutting.



NOTE: Mulching means cutting and returning the grass clippings to the lawn in one step: the grass clippings are cut very fine and then distributed evenly back onto the lawn. Under normal conditions, the mulched grass will biodegrade quickly to provide nutrients to the lawn. Do not attach the grass catcher (20) and the mulching insert (23) at the same time.

1. Open the deflector guard (10), hold the recess handle (23b) in position and insert the mulching insert (23) into the rear discharge chute (21) (Fig. 14). Ensure the locking latch (23a) snap into the rear discharge chute (21).
2. Hold the recess handle (23b) and pull the mulching insert (23) out of the rear discharge chute (21), then remove the mulching insert (23) (Fig. 15).

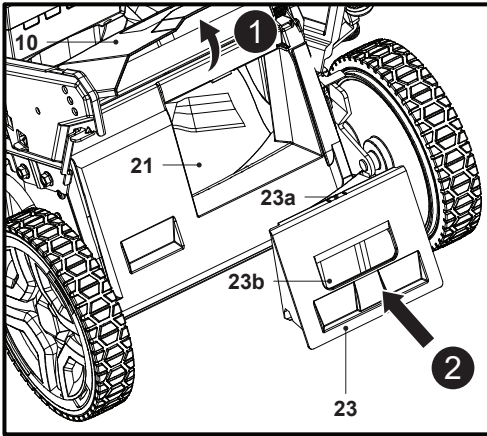

Fig. 14

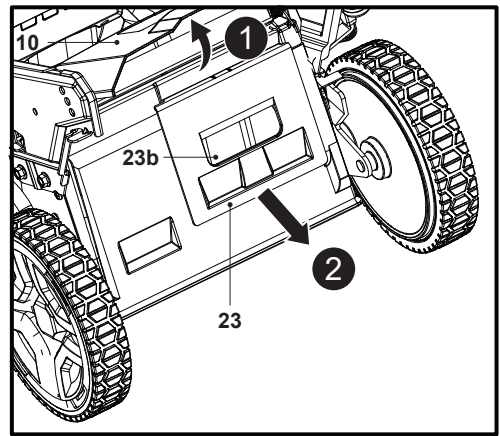

Fig. 15

Side discharge attachment

1. Set the cutting height adjustment lever (18) higher than the second lowest position.
2. Rotate the side deflector guard (16) towards the motor and hold it in position (Fig. 16, step 1).
3. Align and hang the hooks (22a) of the side discharge attachment (22) onto the rods (Fig. 16, step 2).
4. Gently release the side deflector guard (16) (Fig. 17) and the side discharge attachment (22) is ready for use.

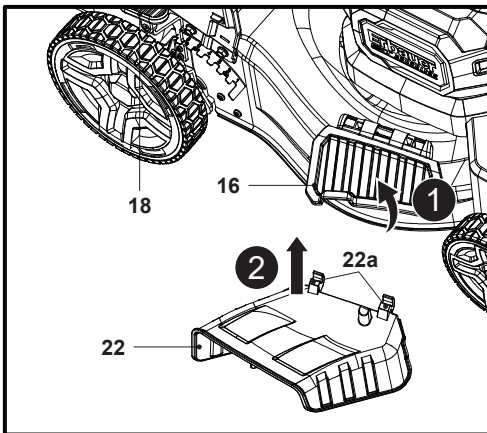

Fig. 16

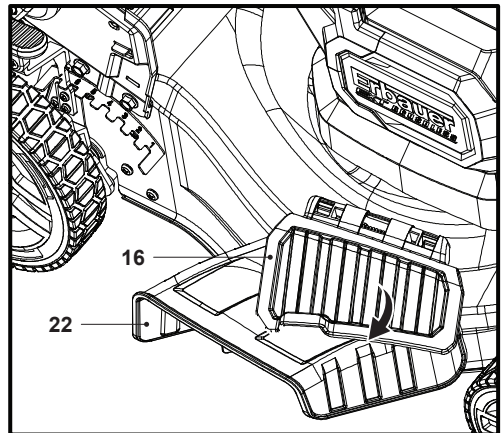

Fig. 17

General operation

1. Check the product, its battery pack and charger as well as accessories for damage before each use. Do not use the product if it is damaged or shows wear. Take care of any problem you find or have the product checked by qualified specialist.
2. Double check that the accessories and attachments are properly fixed.
3. Always push the product using the grip handle (3). Keep the handles dry to ensure safe support.
4. Ensure that the air vents are always unobstructed and clear. Clean them if necessary with a soft brush. Blocked air vents may lead to overheating and damage the product.
5. Switch the product off immediately if you are disturbed while working by other people entering the working area. Always let the product come to complete stop before leaving it unattended.
6. Do not overwork yourself. Take regular breaks to ensure you can concentrate on the work and have full control over the product.



WARNING! IN SOME COUNTRIES REGULATIONS DEFINE AT WHAT TIME OF THE DAY AND ON WHAT SPECIAL DAYS PRODUCTS ARE ALLOWED TO BE USED AND WHAT RESTRICTIONS APPLY! ASK YOUR COMMUNITY FOR DETAILED INFORMATION AND OBSERVE THE REGULATIONS IN ORDER TO PRESERVE A PEACEFUL NEIGHBOURHOOD AND AVOID COMMITTING ADMINISTRATIVE OFFENCES! (STATEMENT NOT REQUIRED FOR THE UK)

Starting/Stopping



WARNING! BEFORE STARTING, PUT THE PRODUCT ON A FLAT SURFACE FREE OF HIGH GRASS! CLEAN THE UNDERSIDE OF THE DECK!

START THE MOTOR CAREFULLY ACCORDING TO INSTRUCTIONS. KEEP YOUR FEET WELL AWAY FROM THE CUTTING BLADE (17C)!

DO NOT TILT THE PRODUCT WHEN STARTING THE MOTOR.

Starting



NOTE: The product can only be started by pressing the safety switch button (1) followed by squeezing the start lever (2) within 5 seconds. Reverse operation or interval between two actions exceeding 5 seconds cannot start the product.

1. Open the battery compartment cover (12) and install the battery pack (24) into the battery compartment (12e).
2. Close the battery compartment cover (12).
3. Stand behind the grip handle (3).
4. While holding the safety switch button (1) pressed (Fig. 18, step 1), pull the start levers (2) towards the grip handle (3) within 5 seconds and hold it in position (Fig. 18, step 2).
5. After the lawn mower starts, release the safety switch button (1).
6. The actual battery capacity will be displayed on the battery display (12c) at the back of battery compartment cover (12).
7. The work lamp (12f) at the front of battery compartment cover (12) will be automatically powered on.

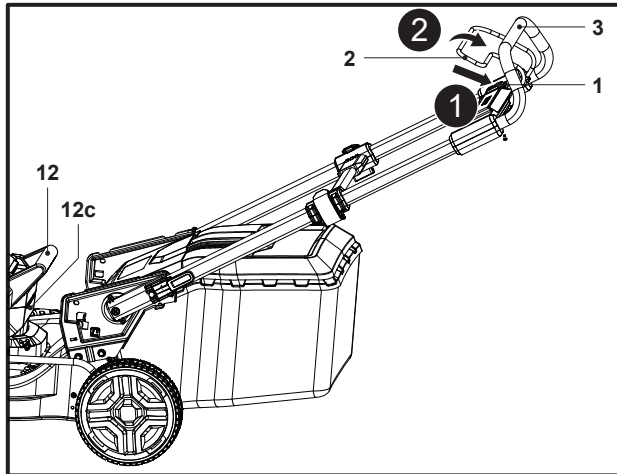

Fig. 18

Stopping

1. Release the start lever (2) to stop the lawn mower (Fig. 19).

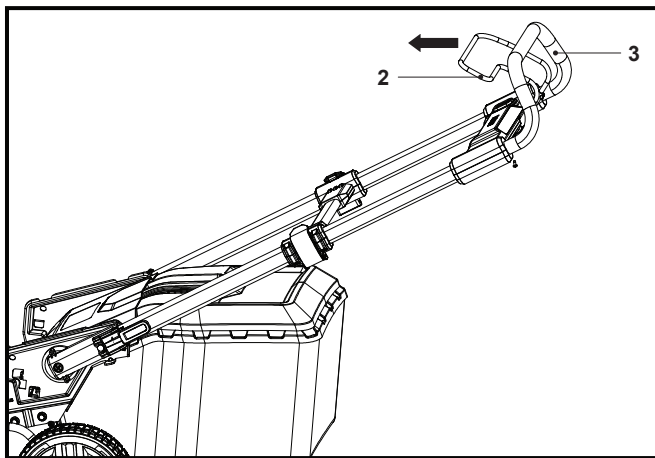

Fig. 19

Mowing

1. Make sure that the lawn is clear of stones, sticks, wire or other objects that could damage the product or its product.
2. Do not cut wet grass because it tends to stick to the underbody of the product, preventing the proper discharge of grass clippings, and it could also cause you to slip and fall.
3. Never cut off more than one-third of the total length of the grass for a healthy lawn. In the autumn, lawns should only be cut as long as there is growth.
4. Slowly push the product forward.
5. Mow in slight overlapping rows. The most effective pattern for mowing lawns is straight lines along one of the sides. This will keep the rows even and ensures that all the lawn is cut without missing any spots (Fig. 20).

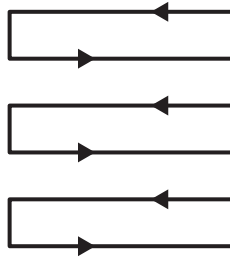

Fig. 20

6. Circle around flower beds. When reaching a flower bed in the middle of the lawn, cut a row or two around the circumference of the bed.
7. Pay special attention when changing direction.
8. Empty the grass catcher (20) regularly.



WARNING! IF THE PRODUCT STRIKES A FOREIGN OBJECT STOP IMMEDIATELY! LET THE PRODUCT COOL DOWN AND THOROUGHLY INSPECT THE PRODUCT FOR DAMAGE! HAVE ANY DAMAGE REPAIRED BEFORE RESTARTING!



EXTENSIVE VIBRATION OF THE PRODUCT DURING OPERATION IS AN INDICATION OF DAMAGE! THE PRODUCT SHOULD BE PROMPTLY INSPECTED AND REPAIRED!

9. Prepare the product according to required application.

Function	Grass catcher	Mulching insert	Side discharge attachment
Grass collection	attached	removed	removed
Mulching	removed	inserted	removed
Side discharge	removed	inserted	attached

Grass collection

1. Remove the mulching insert (23) and attach the grass catcher (20). Make sure the side discharge attachment (22) is not fitted to the product and the side deflector guard (16) is in place.
2. Empty the grass catcher (20) regularly and empty the grass catcher (20) before storage.

Mulching



NOTE: Mulching means cutting and returning the grass clippings to the lawn in one step: the grass clippings are cut very fine and then distributed evenly back onto the lawn. Under normal conditions, the mulched grass will biodegrade quickly to provide nutrients to the lawn.

1. Insert the mulching insert (23) into the rear discharge chute (21), make sure the side discharge attachment (22) and grass catcher (20) are not fitted to the product and the side deflector guard (16) is in place.
2. Avoid mowing when the grass is wet from rain or dew. Wet grass may form clumps which interfere with the mulching action and reduce runtime. The best time to mow grass is late afternoon when the grass is dry and the newly cut area will not be exposed to direct sunlight.

3. Set the cutting height to about one third of the grass blade length, ideally no more than 35 mm at one time for best mulching performance. If the lawn is overgrown, it may be necessary to increase the cutting height to reduce the pushing effort and prevent the motor overloading. For extremely heavy mulching, it is advisable to first cut at a high cutting height, and then again to a lower cutting height. Otherwise, make narrower cuts and mow slowly.
4. Keep the housing free of built-up grass for best performance. From time to time switch the product off and wait for the blade to come to a complete stop. Then turn the product on its side. Using an object such as a wooden stick, remove any accumulation of grass in the blade area. Be careful of the sharp edges of the blade. Clean often after cutting new grass and after every use.
5. Certain types of grass or grass conditions may require an area to be mulched a second time to fully disperse the grass across the lawn. When cutting a second time, it is advisable to cut perpendicular (across) the first cutting pattern. Do not change the cutting pattern in any way that would cause you to mow downhill.
6. Change your cutting pattern from week to week. This will help prevent matting and graining of the lawn.

Side discharging



NOTE: When using the side discharge function, the grass clippings are discharged and spread across the ground.

Attach the side discharge attachment (22). Make sure the mulching insert (23) is inserted and the grass catcher (20) is not fitted to the product.

After use

1. Switch the product off, remove the battery pack (24) and let it cool down.
2. Check, clean and store the machine as described below.

Troubleshooting

Suspected malfunctions are often due to causes that the users can fix themselves. Therefore check the product using this section. In most cases the problem can be solved quickly.



WARNING! ONLY PERFORM THE STEPS DESCRIBED WITHIN THESE INSTRUCTIONS! ALL FURTHER INSPECTION, MAINTENANCE AND REPAIR WORK MUST BE PERFORMED BY AN AUTHORISED SERVICE CENTRE OR A SIMILARLY QUALIFIED SPECIALIST IF YOU CANNOT SOLVE THE PROBLEM YOURSELF!

Problem	Possible cause	Solution
1. Product does not start	1.1. Battery pack is not properly attached	1.1. Attach properly
	1.2. Battery pack is discharged	1.2. Remove and charge battery pack
	1.3. Battery pack is hot	1.3. Remove and let it cool
	1.4. Battery pack is damaged	1.4. Check by a specialist electrician
	1.5. Other electrical defect to the product	1.5. Check by a specialist electrician
2. Product does not reach full power	2.1. Battery pack capacity is too low	2.1. Charge battery pack
	2.2. Air vents are blocked	2.2. Clean the air vents

Problem	Possible cause	Solution
3. Unsatisfactory cutting result	3.1. Cutting blade is dull / damaged	3.1. Replace with a new one
	3.2. Cutting material exceeds capacity	3.2. Only cut materials according to the product capacity.
	3.3. Cutting height is incorrect	3.3. Adjust the cutting height
4. Product suddenly stops	4.1. Battery pack is discharged	4.1. Remove and charge battery pack
	4.2. Battery pack is too hot	4.2. Remove battery pack and let it cool down
	4.3. Cutting blade is blocked	4.3. Remove blockage
5. Excessive vibration or noise	5.1. Cutting blade is dull/damaged	5.1. Replace with a new one
	5.2. Cutting material exceeds capacity	5.2. Only cut materials according to the product capacity
	5.3. Cutting height is incorrect	5.3. Adjust the cutting height
	5.4. Bolts/nuts are loosen	5.4. Tighten bolts/nuts

EN Care and maintenance

The golden rules for care



WARNING! ALWAYS SWITCH THE PRODUCT OFF, REMOVE THE BATTERY PACK (24) AND LET THE PRODUCT COOL DOWN BEFORE PERFORMING INSPECTION, MAINTENANCE AND CLEANING WORK!



ONLY PERFORM CARE AND MAINTENANCE WORK ACCORDING TO THESE INSTRUCTIONS! ALL FURTHER WORKS MUST BE PERFORMED BY A QUALIFIED SPECIALIST!

1. Keep the product clean. Remove debris from it after each use and before storage.
2. Regular and proper cleaning will help ensure safe use and prolong the life of the appliance.
3. Inspect the product before each use for worn and damaged parts. Do not operate it if you find broken and worn parts.



WARNING! ONLY PERFORM REPAIRS AND MAINTENANCE WORK ACCORDING TO THESE INSTRUCTIONS! ALL FURTHER WORKS MUST BE PERFORMED BY A QUALIFIED SPECIALIST!

General cleaning

1. Clean the product with a damp cloth and pH-neutral soap. Use a brush for areas that are hard to reach.
2. In particular clean the switches and air vents (13) after every use with a cloth and brush.
3. Remove stubborn dirt with high pressure air (max. 3 bar).



NOTE: Do not use chemical, alkaline, abrasive or other aggressive detergents or disinfectants to clean this product as they might be harmful to its surfaces.

4. Check for any damage and wear. Repair damages in accordance with this instruction manual or take it to an authorised service centre before using the product again.

Spare parts / Replacement parts

The following parts of this product may be replaced by the consumer. Spare parts are available at an authorized dealer or through our customer service.

Description	EAN
Cutting blade (17c)	Daye 263003499
Battery pack (24)	ERT1044BAT, ERT1045BAT
Charger (25)	ERT1046CHR, ERT1047CHR

Maintenance

Before and after each use, check the product and accessories (or attachments) for wear and damage. If required, exchange them for new ones as described in this instruction manual. Observe the technical requirements.

Underbody and cutting blade



WARNING! WEAR SAFETY GLOVES WHEN WORKING ON THE CUTTING BLADE (17C) AND CLOSE TO IT! USE PROPER MACHINES TO REMOVE DEBRIS, E. G. A WOODEN STICK! NEVER USE YOUR BARE HANDS!



ALWAYS USE ORIGINAL SPARE PARTS FOR REPLACEMENT. THE CUTTING BLADE MUST BE REPLACED BY AN IDENTIFICATION NO. 263003499. DO NOT ATTACH ANY OTHER TYPE OF CUTTING BLADE!



THE REPLACEMENT OF THE CUTTING BLADE SHOULD BE DONE BY A QUALIFIED SPECIALIST! REWORK OR SHARPENING BLADES IS NOT RECOMMENDED UNLESS IT IS DONE BY A REPAIR SERVICE OR A SIMILARLY QUALIFIED SPECIALIST!!

1. Keep the underbody and cutting blade (17c) clean and free of debris. Remove clippings from the rear discharge chute (21).
2. Check all fasteners, such as nuts and bolts, periodically for tightness before operation. After prolonged use, especially in sandy soil conditions, the cutting blade will become worn and lose some of the original shape. The cutting efficiency will be reduced and the cutting blade should be replaced.
3. Keep the cutting blade (17c) sharp to ensure a good cutting performance. Replace a worn or damaged cutting blade with a new one of the same type or have it sharpened by a qualified specialist.
4. Loosen the hex bolt (17d) anti-clockwise using a suitable wrench (Size 13 mm) and remove it together with the cutting blade (17c) and the blade holder (17b).
5. Replace the cutting blade (17c) with a new one of the same type. Check the status of blade holder (17b) onto the spindle (17a) firstly, then attach the cutting blade (17c) to the blade holder (17b) by aligning it with the correct semi-circle patterns, fit the hex bolt with washers (17d) properly to secure the connection. Tighten the hex bolt (17d) clockwise with 25 Nm min, 35 Nm max. to ensure safe operation of your product (Fig. 21).
6. Replace this cutting blade (17c) after 50 hours mowing or 2 years whichever is sooner regardless of condition. If the cutting blade (17c) is cracked or damaged, you must immediately replace it with a new one.
7. Lubricate the cutting blade (17c) after each use to prolong the life span of cutting blade and product. Apply light machine oil along the edge of the cutting blade.

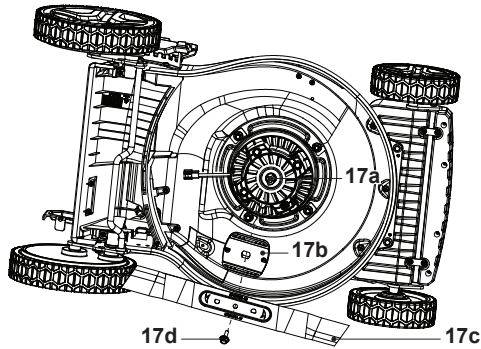

Fig. 21

Grass catcher

1. Inspect the grass catcher (20) before each use. Do not use it if you find any damage.
2. Clean the grass catcher (20) after operation using water and mild soap.
3. Let the grass catcher (20) dry thoroughly before storing to avoid mildew.

Control cord

Check the control cord (4) before each use.



WARNING! DO NOT USE THE PRODUCT WITH A DEFECTIVE OR A LOOSE CONTROL CORD (4)!

Repair

This product does not contain any parts that can be repaired by the consumer. Contact an authorised service centre or a similarly qualified person to have it checked and repaired.

Storage

1. Switch the product off and remove the battery pack (24) before storage.
2. Clean the product as described above.
3. Suggest folding the handle assembly and storing the product vertically to save space (Fig. 22).

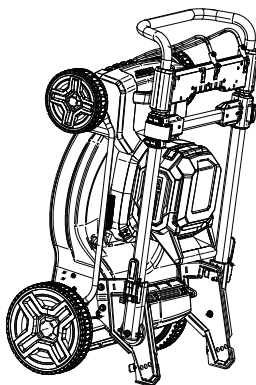

Fig. 22

4. Store the product and its accessories in a dark, dry, frost-free, well-ventilated place.
5. Always store the product in a place that is inaccessible to children. The ideal storage temperature is between 10 °C and 30 °C.
6. We recommend using the original package for storage or covering the lawn mower (without battery pack) with a suitable cloth or enclosure to protect it against dust.
7. Charge the battery pack to 3 bars on the light indicator before storage.

Transportation



1. Switch the product off and remove the battery pack (24) before transporting it anywhere.
2. Attach transportation guards, if applicable.
3. Always transport the product by its transport handles (11, 14).
4. Protect the product from any heavy impact or strong vibrations which may occur during transportation in vehicles.
5. Secure the product to prevent it from slipping or falling over, damage and injury.

Customer care and technical helpline

A better way to repair your tools

Kingfisher takes special care in creating high-quality garden power tools that are designed to last. But if a fault develops with your garden power tool and you need to claim under the guarantee, the Customer Care and Technical Helpline can support with technical assistance or if required, arrange a free courier collection from your home, assess your garden power tool for fault, repair it, and return it.

Deciding to repair your product rather than buying a replacement and adding to the mountain of waste is a more sustainable choice and you will be doing your bit for the environment.

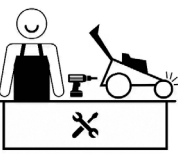
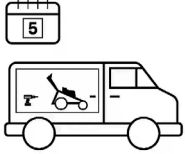
How does it work?				
				
Step 1	Step 2	Step 3	Step 4	Step 5
Find your proof of purchase and get in touch with the Customer Care and Technical Helpline.	Chat to them about the problem with your tool.	They will provide technical and user advice or alternatively arrange a courier collection from your home.*	The team will assess and test and if necessary, repair your product back to full working order.	Your repaired tool will be returned to you via courier within 5 working days*.

Get in touch

If you need help or more information, please contact the Customer Care and Technical Helpline:

UK: 0800 0789647

Eire: 1800 932226

Opening hours are Monday – Friday, 8am-5pm

Availability of spare parts

Contact the customer service helpline for assistance or visit www.kingfishersparses.com

For assistance contact the customer services helpline:

UK 0800 0789647 uk@Kingfisherservice.com

EIRE 1800 932226 eire@kingfisherservice.com

Further information about this product can also be found at:

www.kingfisher.com/products



(UK) DECLARATION OF CONFORMITY

Product

- 36 V Lawn Mower
- ERT1042GLM
- SN: 000001-999999

Name and address of the manufacturer or his authorised representative:

Kingfisher International Products Limited,
1 Paddington Square,
London, W2 1GG,
United Kingdom

This declaration of conformity is issued under the sole responsibility of the manufacturer.

Object of the declaration

Product	Model	EAN
36 V Lawn Mower	ERT1042GLM	5059340904955

The object of the declaration described above is in conformity with the relevant legislation:

Supply of Machinery (Safety) Regulations 2008 as amended
Electromagnetic Compatibility Regulations 2016 as amended
The Restriction of the use of Certain Hazardous Substances in Electrical and Electronic Equipment Regulations 2012 as amended
2012/19/EU as amended Waste Electrical and Electronic Equipment (WEEE)
Regulation (EC) No 1907/2006, concerning the Registration, Evaluation, Authorization and Restriction of Chemicals (REACH)

References to the relevant designated standards used or references to the other technical specifications in relation to which conformity is declared:

BS EN 62841-1:2015+A11
BS EN IEC 62841-4-3:2021+A11
BS EN IEC 55014-1:2021
BS EN IEC 55014-2:2021
BS EN 62233: 2008
BS EN 61000-3-2: 2019
BS EN 61000-3-3: 2013+A1: 2019

Name, address and identification number of the Approved Body: TUV Rheinland UK Ltd.
1011 Stratford Road, Shirley, Solihull, West Midlands, B90 4BN
UK Approved Body Number : 2571
Number of the type-examination certificate: xxxxxxxxxxxx

Signed for and on behalf of:

Kingfisher International Products Limited,
1 Paddington Square,
London, W2 1GG,
United Kingdom

David Awe
Group Quality Director

On: 04/30/2022



(EN) EU DECLARATION OF CONFORMITY
(FR) DÉCLARATION UE DE CONFORMITÉ
(PL) DEKLARACJA ZGODNOŚCI UE
(RO) DECLARAȚIA DE CONFORMITATE UE
(ES) DECLARACIÓN UE DE CONFORMIDAD
(PT) DECLARAÇÃO DE CONFORMIDADE UE

Product/ Produit/ Produkt/Produsul/Produkt/Producto/Produto

- 36 V Lawn Mower
- ERT1042GLM
- SN: 000001-999999

Name and address of the manufacturer or his authorised representative:
Nom et adresse du fabricant ou de son mandataire:
Nazwa i adres producenta lub jego upoważnionego przedstawiciela:
Denumirea și adresa producătorului sau a reprezentantului său autorizat:
Nombre y dirección del fabricante o de su representante autorizado:
Nome e endereço do fabricante ou do respetivo mandatário:

Kingfisher International Products B.V.,
Rapenburgerstraat 175E,
1011 VM Amsterdam,
The Netherlands

This declaration of conformity is issued under the sole responsibility of the manufacturer.
La présente déclaration de conformité est établie sous la seule responsabilité du fabricant.
Niniejsza deklaracja zgodności wydana zostaje na wyłączną odpowiedzialność producenta.
Prezenta declarație de conformitate este emisă pe răspunderea exclusivă a producătorului.
La presente declaración de conformidad se expide bajo la exclusiva responsabilidad del fabricante.
A presente declaração de conformidade é emitida sob a exclusiva responsabilidade do fabricante.

Object of the declaration/Objet de la declaration/Przedmiot deklaracji/Obiectul declarației/Objeto de la declaración/Objeto da declaração

Product/Produit/Produkt/ Produsul/ Producto/Produto	Model/Modèle/Model/ Modelul/Modelo/Modelo	EAN
36 V Lawn Mower	ERT1042GLM	5059340904955 / 5059340904542 / 5063022544469

The object of the declaration described above is in conformity with the relevant Union harmonisation legislation:
L'objet de la déclaration décrit ci-dessus est conforme à la législation d'harmonisation de l'Union applicable:
Wymieniony powyżej przedmiot niniejszej deklaracji jest zgodny z odpowiednimi wymaganiami unijnego prawodawstwa harmonizacyjnego:
Obiectul declarației descris mai sus este în conformitate cu legislația relevantă de armonizare a Uniunii:
El objeto de la declaración descrita anteriormente es conforme con la legislación de armonización pertinente de la Unión:
O objeto da declaração acima descrito está em conformidade com a legislação de harmonização da União aplicável:

2006/42/EC as amended Machinery Directive
2014/30/EU as amended Directive Electromagnetic compatibility
2011/65/EU, (EU) 2015/863 as amended Directive Restriction of the use of certain hazardous substances in electrical and electronic equipment
2012/19/EU as amended Waste Electrical and Electronic Equipment (WEEE)
Regulation (EC) No 1907/2006, concerning the Registration, Evaluation, Authorization and Restriction of Chemicals (REACH)

References to the relevant harmonised standards used or references to the other technical specifications in relation to which conformity is declared:
Références des normes harmonisées pertinentes appliquées, y compris la date de celles-ci, ou des autres spécifications techniques, y compris la date de celles-ci, par rapport auxquelles la conformité est déclarée:
Odwołania do odnośnych norm zharmonizowanych, które zastosowano, wraz z datą normy, lub do innych specyfikacji technicznych, wraz z datą specyfikacji, w odniesieniu do których deklarowana jest zgodność:
Trimiteri la standardele armonizate relevante folosite, inclusiv data standardului, sau trimiteri la celelalte specificații tehnice, inclusiv data specificațiilor, în legătură cu care se declară conformitatea:
Referencias a las normas armonizadas pertinentes utilizadas, incluidas las fechas de las normas, o referencias a las otras especificaciones técnicas, incluidas las fechas de las especificaciones, respecto a las cuales se declara la conformidad:
Referências às normas harmonizadas aplicáveis utilizadas, incluindo a data da norma, ou às outras especificações técnicas, incluindo a data da especificação, em relação às quais é declarada a conformidade:

EN 62841-1:2015+A11
EN IEC 62841-4-3:2021+A11
EN IEC 55014-1:2021
EN IEC 55014-2:2021
EN 62233: 2008
EN 61000-3-2: 2019
EN 61000-3-3: 2013+A1: 2019

Name, address and identification number of the notified body: TÜV Rheinland LGA Products GmbH
Tillystraße 2 - 90431 Nürnberg, Germany No.0197
Number of the EC type-examination certificate: xxxxxxxxxx

Authorized Signatory and technical file holder/ Signataire et responsable de la documentation technique autorisé/ Podmiot uprawniony do wystawienia i adres przechowywania dokumentacji technicznej/ Semnatar autorizat și deținătorul dosarului ethnic/ Firmante autorizado y titular del expediente técnico/ Signatário autorizado e detentor da ficha técnica:

Kingfisher International Products B.V.,
Rapenburgerstraat 175E,
1011 VM Amsterdam,
The Netherlands



David Awe
Group Quality & Sustainability Director

: 04/30/2022

Manufacturer:

UK Manufacturer:

Kingfisher International Products Limited,
1 Paddington Square, London, W2 1GG,
United Kingdom

EU Manufacturer:

Kingfisher International Products B.V.
Rapenburgerstraat 175E
1011 VM Amsterdam
The Netherlands

EN www.diy.com
www.screwfix.com
www.screwfix.ie

**To view instruction manuals online,
visit www.kingfisher.com/products**